

Perimeter Seal Installation Instructions

Note: Doors are not supplied with Perimeter Seal or fasteners. These items must be purchased separately.

Note: The Perimeter Seal shown here has a vinyl flap. Perimeter Seal is available with no flap. Skip Step 8 for seal with no vinyl flap.

Note: A Hacksaw is required for smooth, accurate cuts.

Step 1: Measure horizontally across the top of your Header (Fig 1). This may require two people to hold the tape measure.

Step 2: Mark your first piece of Perimeter Seal for cutting (Fig 2).

Step 3: Using a Hack Saw (Fig 3), carefully cut the Perimeter Seal to length.

Step 4: Starting at the end (Fig 4), tap the fasteners halfway into the seal, beginning at 6" from the end and continuing every 12" on center.

Step 5: Holding the seal in place (the edge with the flap should be flush with the inside of the jamb) (Fig 5 & 6), hammer the fasteners partially into the jamb. This will allow for slight adjustments later.

Step 6: Measure the vertical (left side) of your Jamb (Fig 1). Mark your second piece of Perimeter Seal for cutting (Fig 2).

Step 7: Using a Hack Saw (Fig 3), carefully cut the Perimeter Seal to length.

Step 8: Cut a 45° angle through the molding where it meets the top, horizontal piece (Fig 7). This will allow the flap on the horizontal seal to lay down flush with your door.

Step 9: Starting at the top (Fig 4), tap the fasteners halfway into the seal, beginning at 6" from the top and continuing every 12" on center.

Step 10: Holding the seal in place (the edge with the flap should be flush with the inside of the jamb) (Fig 8), hammer the fasteners partially into the jamb. This will allow for slight adjustments later.

Repeat Steps 6 - 10 for the right side Perimeter Seal.

Step 11: When your door is installed, balanced and closed with either the operator or lock, you may completely nail the Perimeter Seal to the jambs (making any slight adjustments as required).

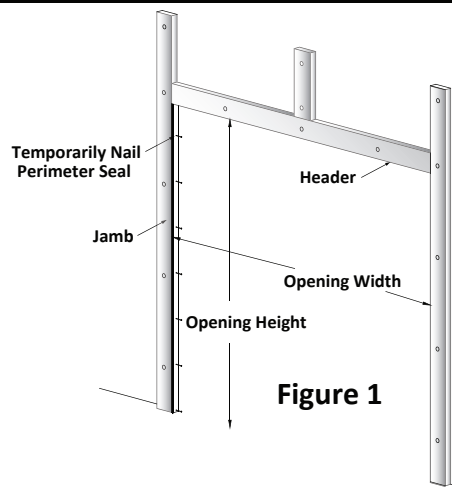

Figure 1

Figure 2

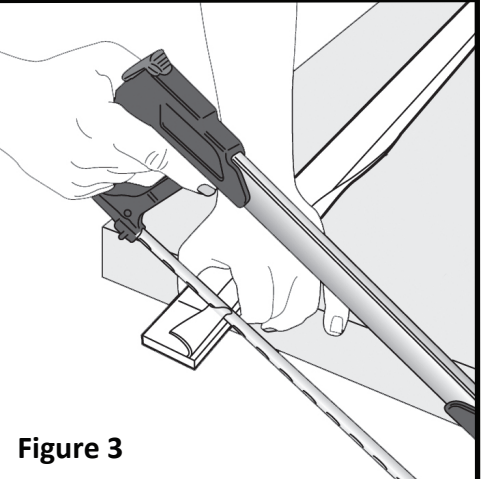
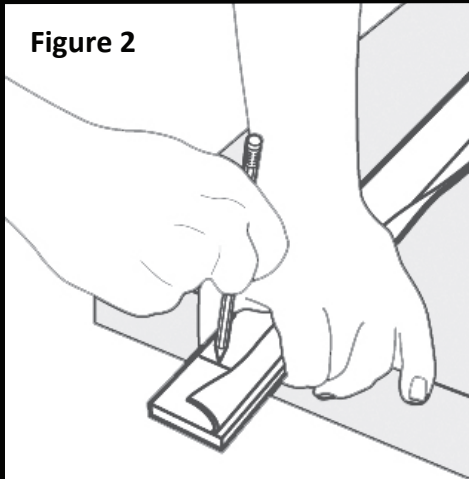

Figure 3

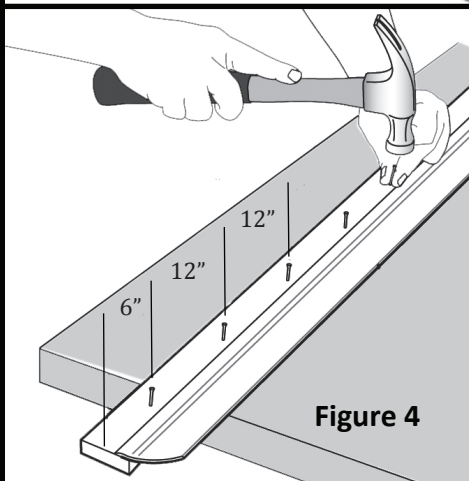

Figure 4

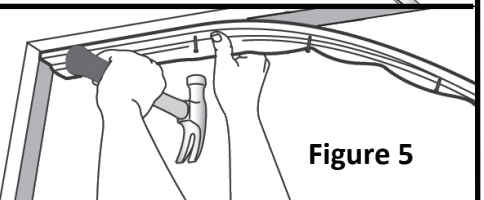

Figure 5

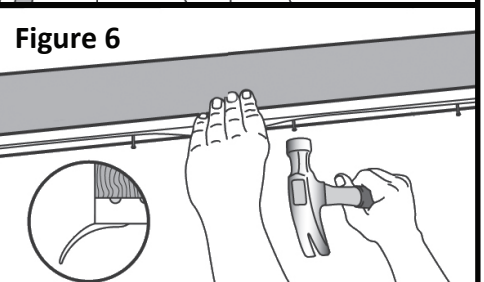

Figure 6

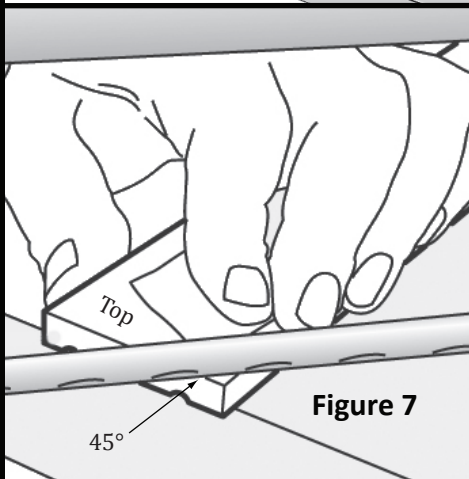

Figure 7

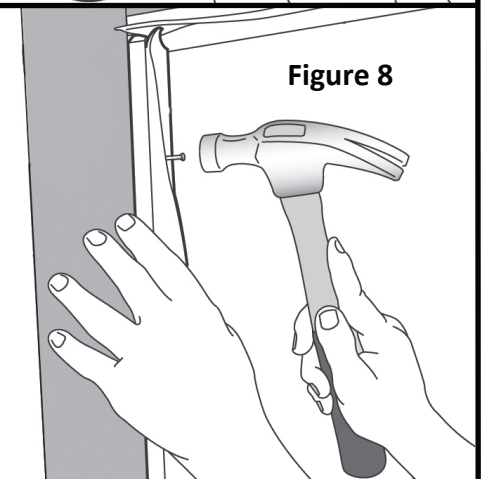

Figure 8